









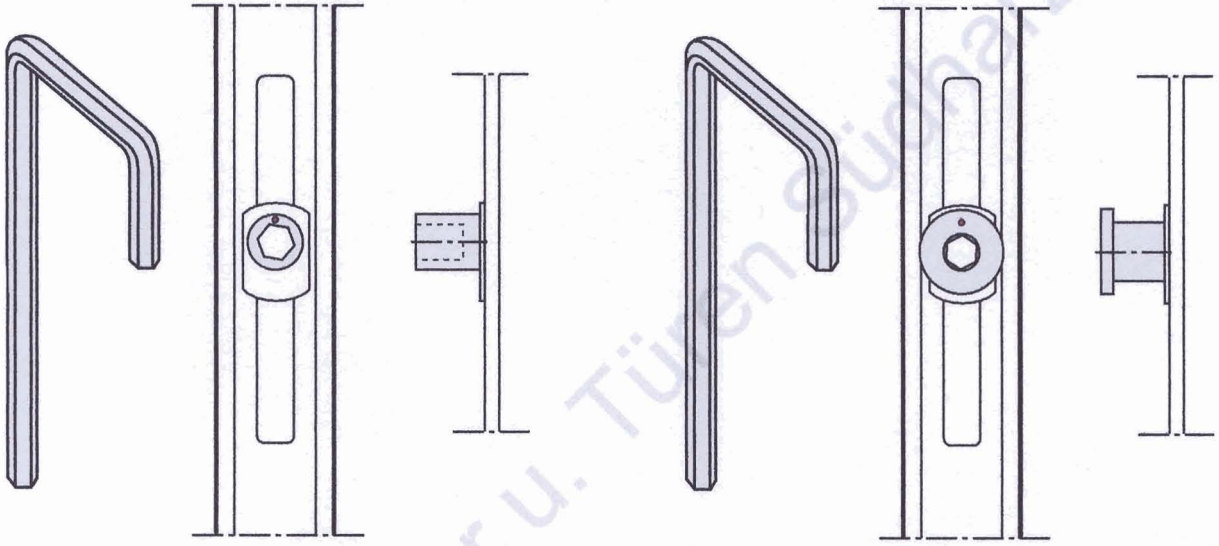

## Verstellhinweise Schließzapfen.

Schließzapfen <b>E</b>	Verstellweg in °	Anpressdruckverstellung in mm	Schließzapfen <b>P</b>	Verstellweg in °	Anpressdruckverstellung in mm
	Grundstellung 	-		Grundstellung 	-
	 90°	+/- 0,8		 90°	+/- 0,8

Schließzapfen <b>V</b>	Verstellweg in °	Anpressdruckverstellung in mm	Höhenverstellung in mm
	Grundstellung 	-	-
	 90°	+/- 0,8	+/- 0,2
	 180°	-	+/- 0,4
	 270°	+/- 0,8	+/- 0,6
	 360°	-	+/- 0,8

0 = Grundstellung

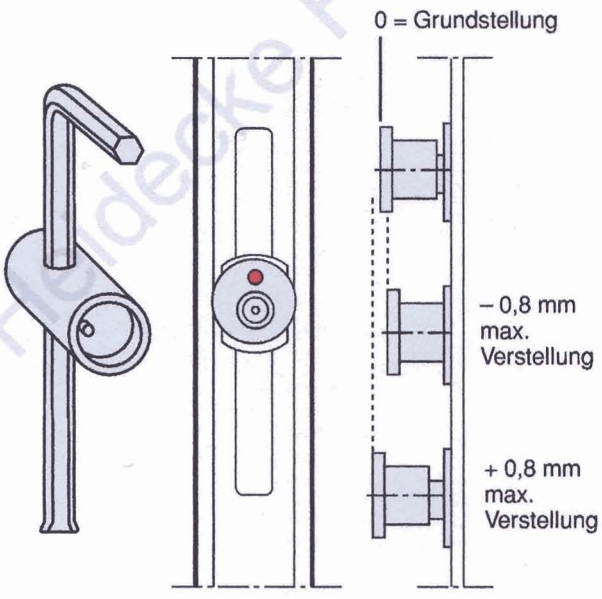
- 0,8 mm max. Verstellung

+ 0,8 mm max. Verstellung

# ROTO NT

## Bandseiten K, A, E5

### Verstellhinweise.

Nur für  
Fachpersonal!

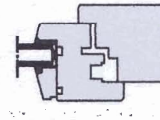
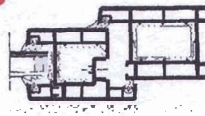

Das Verstellen der ROTO Beschlagteile darf nur von autorisiertem Fachpersonal ausgeführt werden.

Kunststofffenster und -türen  
Bandseite K

Bandseite A\*

Holzfenster und -türen  
Bandseite E5

Bandseite A\*

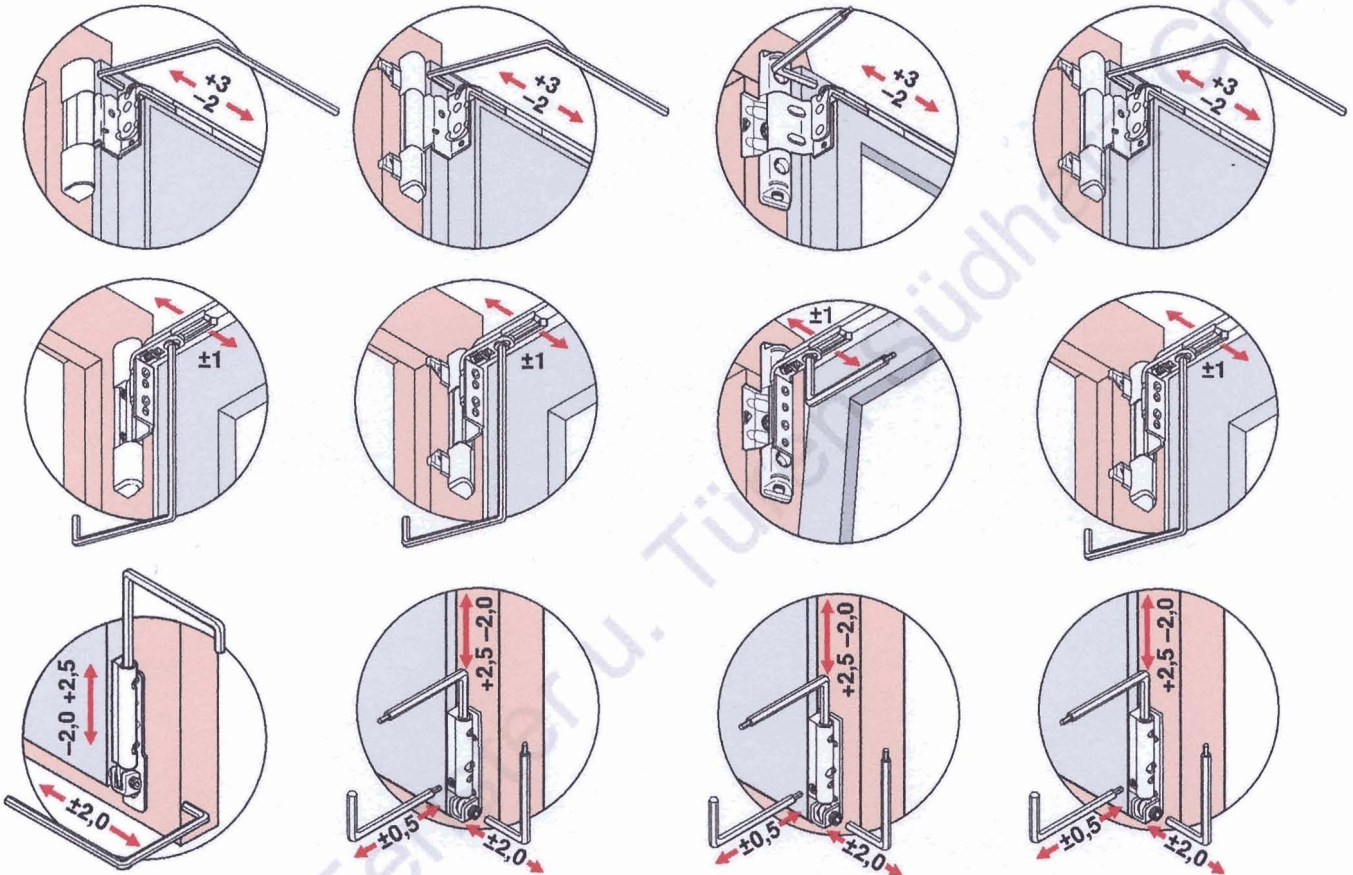

#### Verstellwerkzeuge:

Sechskant-Schraubendreher 4 mm  
P 010 A 2100



Sechskant-Schraubendreher 2,5/4 mm  
P 010 A 2400



\* Bei Einsatz von Abdeckkappen (Axerlager/Ecklager) und Eckbandsicherung ändern sich die angegebenen Verstellmaße.

ROTO FRANK AG  
Stuttgarter Straße 145-149  
70771 Leinfelden-Echterdingen  
Telefon: 0711/7598-0  
Telefax: 0711/7598-253  
Internet: www.ROTO.de  
E-Mail: info@ROTO-frank.com

